



MN SERIES

These ergonomic mini-clamps are designed to make light work of measuring low and medium currents from 0.01 A to 240 A AC.

The shape of the jaws makes 'hooking' onto cables easy, even in areas of restrictive access. The jaws can grip conductors up to 20 mm in diameter.

Depending on the particular model, they have one or two calibres. The output is via either jack sockets or a lead with 4 mm Ø plugs, hence these clamps are compatible with all multimeters and testers on the market.

There are two types of MN series clamps available. The first kind operates as a current transformer (ratio 1,000/1) and gives a current output (mA) for use with any tester with current calibres.

The second type gives a voltage output (DC or AC depending on the model) proportional to the measured current (1, 10, 100 or 1,000 mV/A). This voltage output means that, even with testers without any current calibres, it is possible to measure currents by means of the DC or AC voltage calibres.

There are specific models in the MN series that have been designed with particular applications in mind such as measurement on current transformer outputs, on oscilloscopes and even of leakage currents.

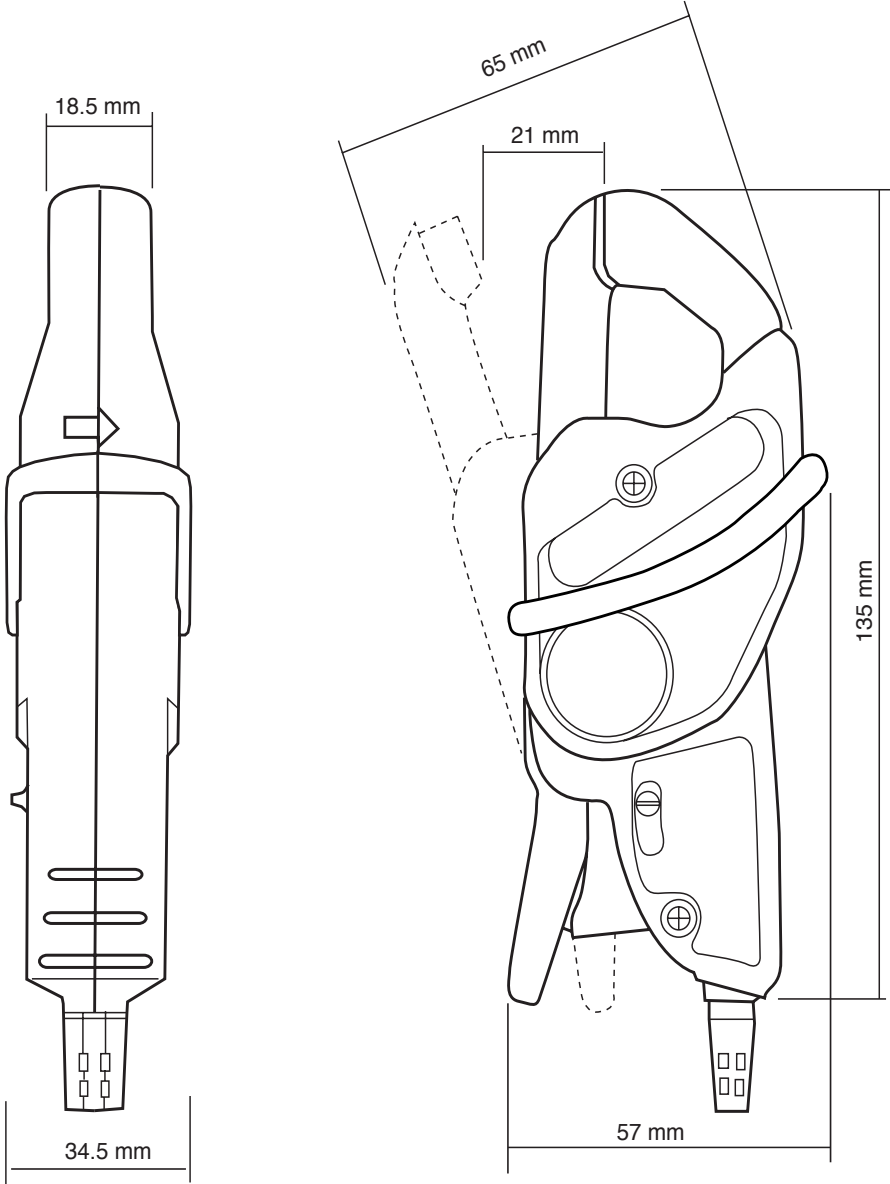

Model MN60 (insulated AC current probe)

Current	60 A peak	600 A peak
Output	100 mV/A	10 mV/A

DESCRIPTION

This 200 A AC clamp enables easy display and measurement of "current" curves. It fits any oscilloscope since it has a coaxial lead with BNC plug. It produces a mV signal directly proportional to current. It offers 2 different sensitivities.

ELECTRICAL SPECIFICATIONS

- Current range:**
0.1 A AC .. 20 A AC (60 A peak)
0.5 A AC .. 200 A AC (600 A peak)
- Output signal:**
100 mV AC / A AC (2 V for 20 A)
10 mV AC / A AC (2 V for 200 A)

- Accuracy and phase shift ⁽¹⁾:**

Calibre	20 A		200 A		
	0.1 A .. 20 A	0.5 A .. 10 A	10 A .. 40 A	40 A .. 100 A	100 A .. 240 A
Primary current					
% Accuracy of output signal	≤ 2% + 50 mV	≤ 3.5% + 5 mV	≤ 3% + 5 mV	≤ 2.5% + 5 mV	≤ 1.5% + 5 mV
Phase shift	not specified	not specified	≤ 6°	≤ 4°	≤ 3°

- Bandwidth:**
40 Hz .. 40 kHz (-3 dB) (depending on current value)
- Rise/fall time from 10 % to 90 %:**
 - 20 A calibre: 7.4 μs
 - 200 A calibre: 8.7 μs
- 10 % delay time:**
0.1 μs
- Ampere second product:**
 - 20 A calibre: 25 A.s
 - 200 A calibre: 2 A.s
- Insertion impedance (at 400 Hz / 10 kHz)**
 - 20 A calibre: < 0.3 mΩ / < 7.2 mΩ
 - 200 A calibre: < 1 mΩ / < 26 mΩ
- Maximum currents:**
200 A continuous for a frequency ≤ 3 kHz (limitation proportional to inverse of one third of frequency beyond)
- Influence of temperature:**
≤ 150 ppm / k or 0.15 % of output signal per 10 °K
- Influence of relative humidity:**
< 0.2 % of output signal
- Influence of adjacent conductor:**
≤ 15 mA/A at 50 Hz
- Influence of DC current < 10 % of rated calibre superimposed on the rated current:**
 - 20 A calibre:
For I DC < 2 A: influence < 0.5 %
 - 200 A calibre:
For I DC < 20 A: influence < 5 %
- Influence of conductor position in jaws:**
≤ 0.5 % of output signal at 50/60 Hz

- Influence of frequency ⁽²⁾:**
 - 20 A calibre:
< 10 % of output signal from 40 Hz .. 1 kHz
< 15 % of output signal from 1 kHz .. 10 kHz
 - 200 A calibre:
< 3 % of output signal from 40 Hz .. 1 kHz
< 12 % of output signal from 1 kHz .. 10 kHz
- Influence of crest factor:**
< 3 % of output signal for a crest factor of 3 and current of 200 A_{RMS}

MECHANICAL SPECIFICATIONS

- Operating temperature:**
-10 °C to +55 °C
- Storage temperature:**
-40 °C to +70 °C
- Relative humidity for operation:**
0 to 85 % RH decreasing linearly above 35 °C
- Operating altitude:**
0 to 2,000 m
- Max. jaw opening:**
20 mm
- Clamping capacity:**
Cable: Ø max 20 mm
Busbar: 1 busbar of 20 x 5 mm
- Casing protection rating:**
IP40 (IEC 529)
- Drop test:**
1 m (IEC 68-2-32)
- Shock resistance:**
100 g / 6 ms / half-periode (IEC 68-2-27)

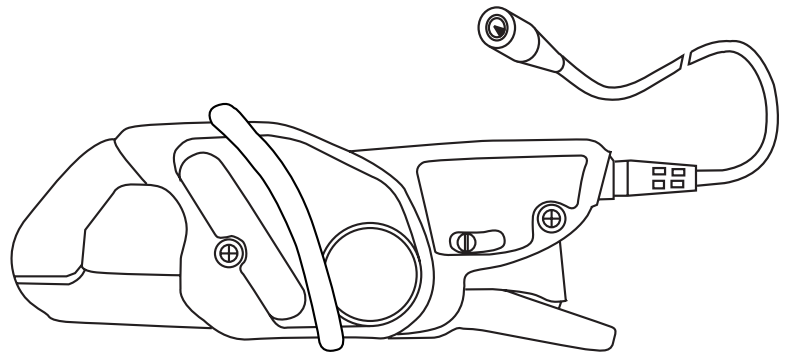

- Protection against impacts:**
IK04 0.5 J (EN 50102)
- Vibration resistance:**
10/55/10 Hz, 0.15 mm (IEC 68-2-6)
- Self-extinguishing capability:**
Casing: UL94 V2
Jaws: UL94 V0
- Dimensions:**
128 x 49 x 28 mm
- Weight:**
180 g
- Colours:**
Dark grey case with red jaws
- Output:**
Coaxial cable 2 m long, terminated by an insulated BNC connector

SAFETY SPECIFICATIONS

- Electrical safety:**
Instrument with double insulation or reinforced insulation between the primary, the secondary and the grippable part located under the guard as per IEC 1010-1 & IEC 1010-2-032
- 600 V category III, pollution degree 2
- 300 V category IV, pollution degree 2
- Electromagnetic compatibility (EMC):**
EN 50081-1: class B
EN 50082-2:
- Electrostatic discharge: IEC 1000-4-2
4 kV level 2 performance criterion B
8 kV in the air level 3 performance criterion B
- Radiated field: IEC 1000-4-3
10 V/m performance criterion A
- Fast transients: IEC 1000-4-4
1 kV level 2 performance criterion B
2 kV level 3 performance criterion B
- Magnetic field at 50/60 Hz: IEC 1000-4-8
field of 400 A/m at 50 Hz: < 1 A

CURVES AT 50 Hz

200 A calibre

20 A calibre

Error on measurement

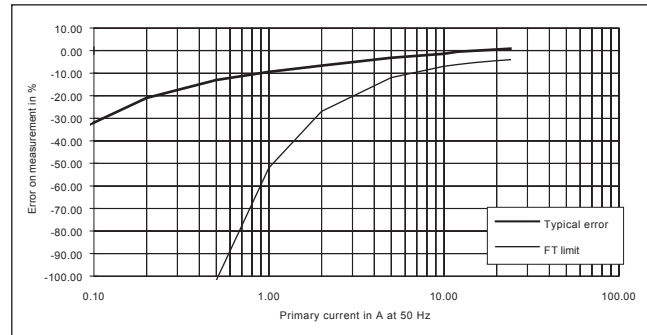
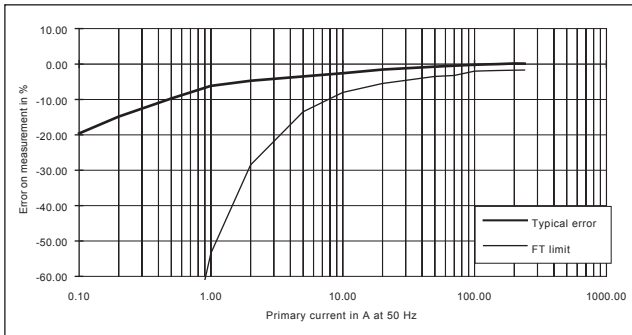

Phase shift

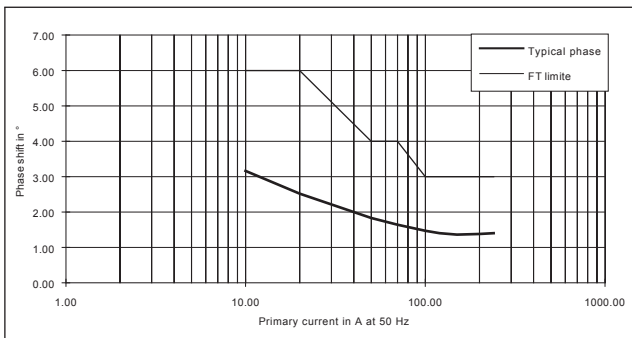

FREQUENCY RESPONSE

200 A calibre

20 A calibre

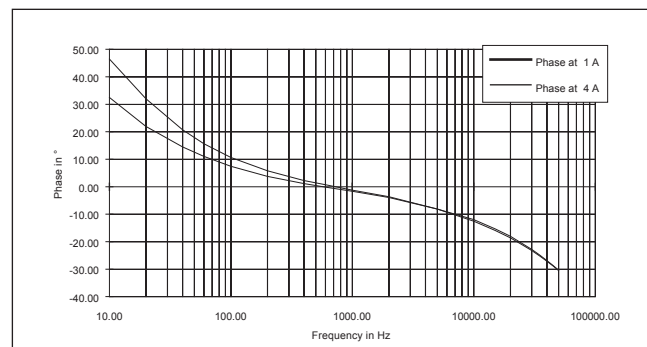
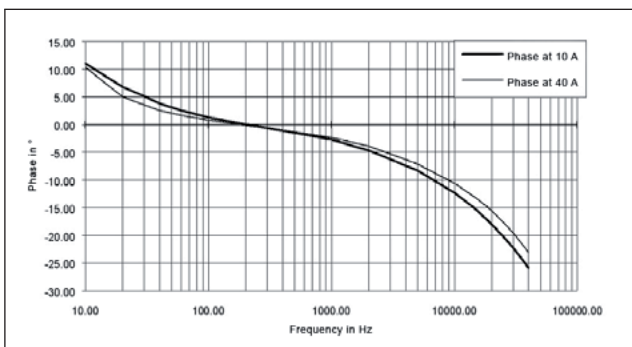
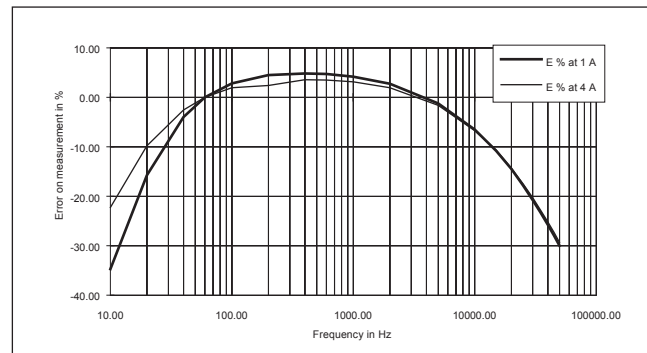
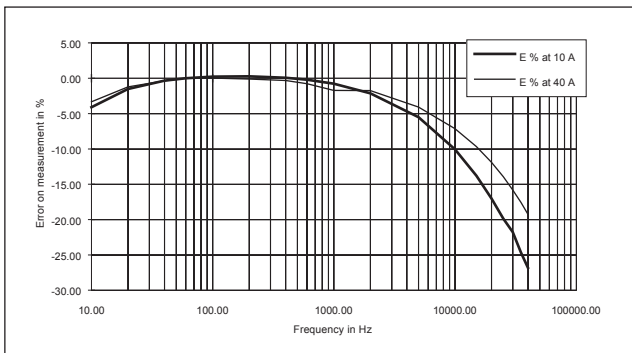

FREQUENCY RESPONSE (CONT.)

200 A calibre

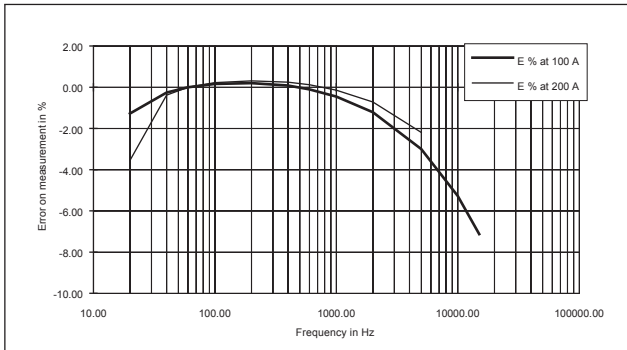

20 A calibre

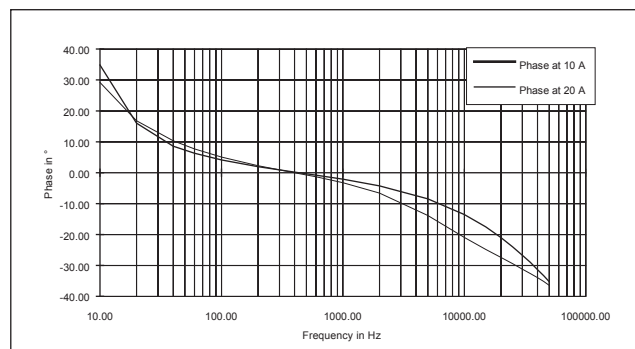
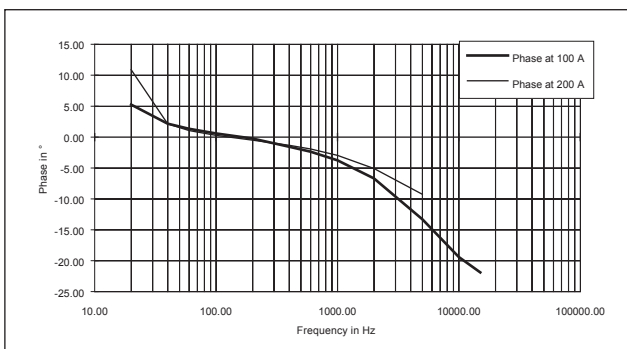
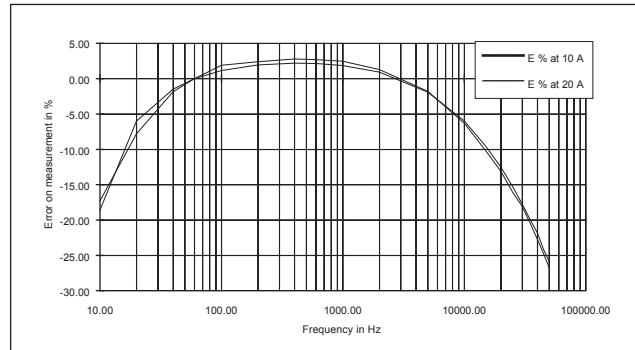

RESPONSE TO A SQUARE SIGNAL

200 A calibre

20 A calibre

10 A at 10 Hz

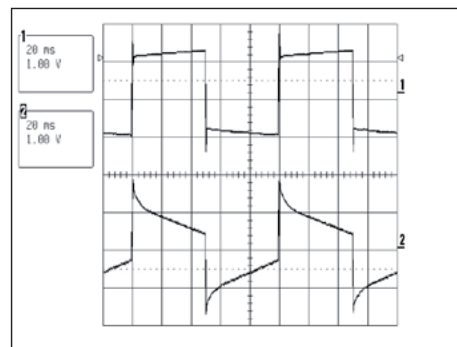
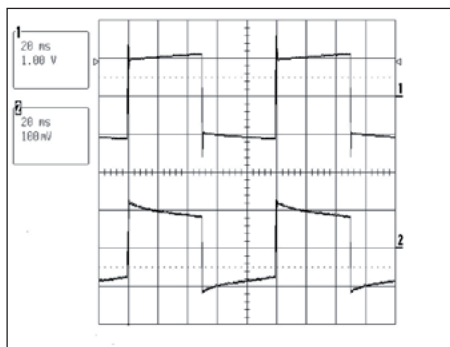

10 A at 100 Hz

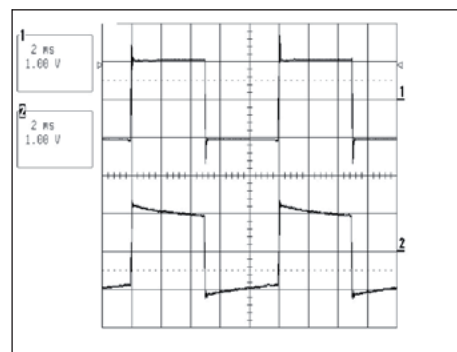
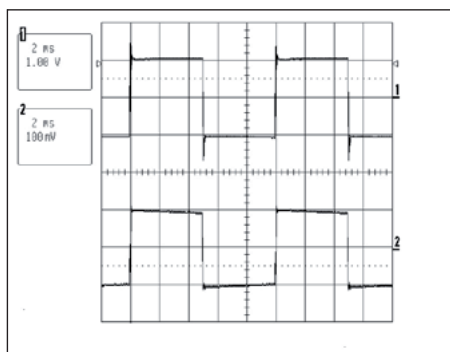



RESPONSE TO A SQUARE SIGNAL (CONT.)

200 A calibre

20 A calibre

10 A at 1 kHz

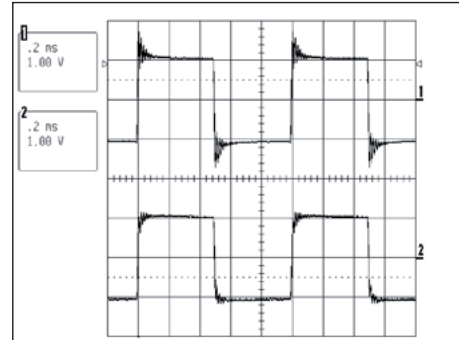
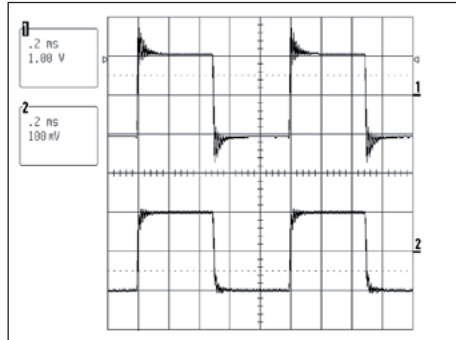

10 A at 10 kHz

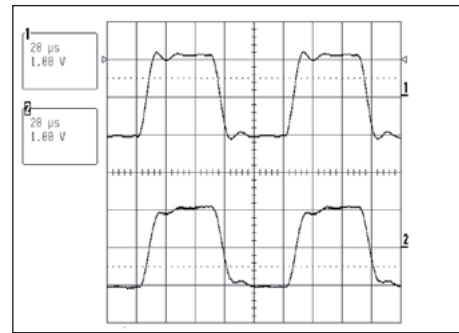
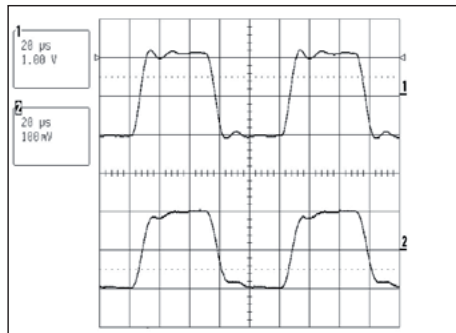

(1) Conditions of reference: 23 °C ± 3 °K, 20 % to 75 % RH, sinusoidal signal with frequency of 48 Hz at 1 kHz, external magnetic field < 40 A/m, no DC components, no external conductor with circulating current, conductor centred for measurement, load impedance > 1 MΩ and < 100 pF.
 (2) Out of reference domain

To order	Reference
AC current clamp model MN60 for oscilloscope with operating manual	P01120409