



MN SERIES

These ergonomic mini-clamps are designed to make light work of measuring low and medium currents from 0.01 A to 240 A AC.

The shape of the jaws makes 'hooking' onto cables easy, even in areas of restrictive access. The jaws can grip conductors up to 20 mm in diameter.

Depending on the particular model, they have one or two calibres. The output is via either jack sockets or a lead with 4 mm Ø plugs, hence these clamps are compatible with all multimeters and testers on the market.

There are two types of MN series clamps available. The first kind operates as a current transformer (ratio 1,000/1) and gives a current output (mA) for use with any tester with current calibres.

The second type gives a voltage output (DC or AC depending on the model) proportional to the measured current (1, 10, 100 or 1,000 mV/A). This voltage output means that, even with testers without any current calibres, it is possible to measure currents by means of the DC or AC voltage calibres.

There are specific models in the MN series that have been designed with particular applications in mind such as measurement on current transformer outputs, on oscilloscopes and even of leakage currents.

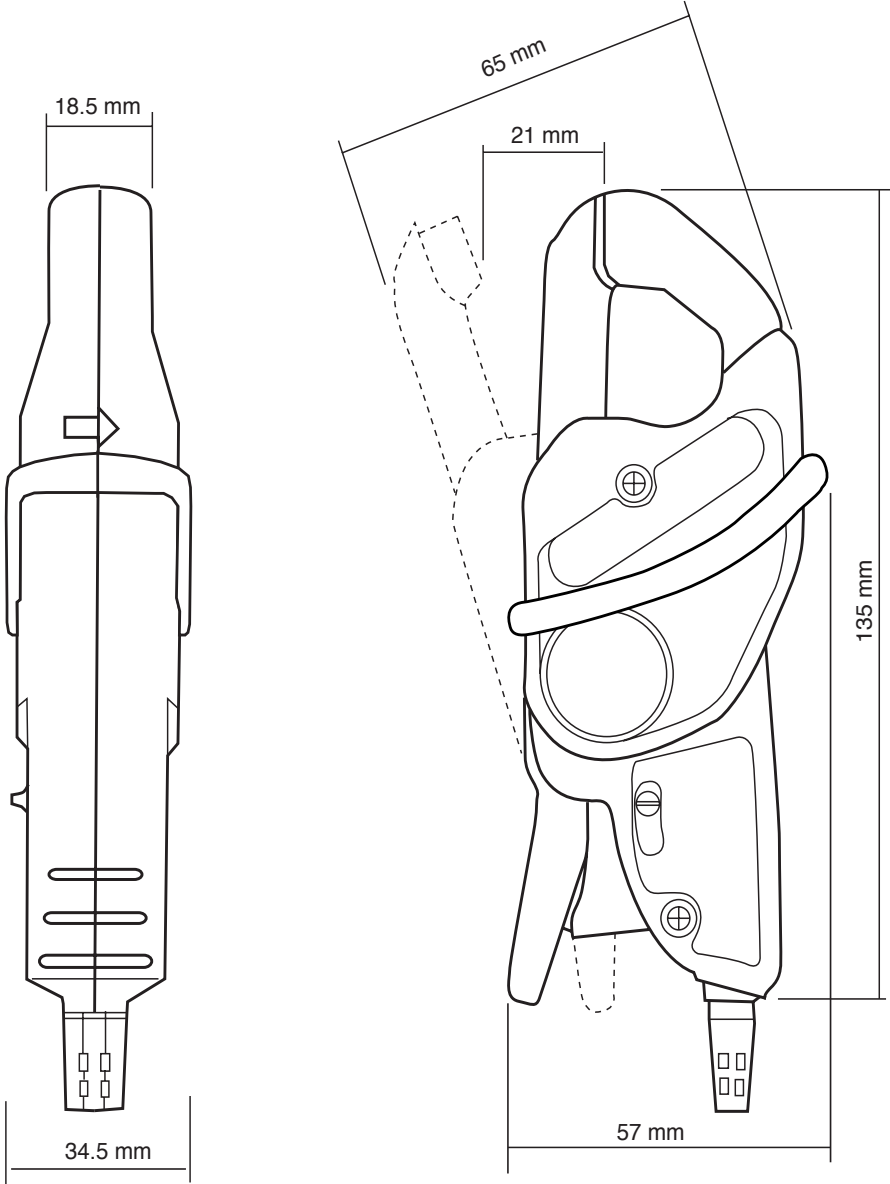

Model MN71

Current	10 A AC
Output	100 mV/A

DESCRIPTION

This clamp was specially designed to measure current on current transformer secondary circuits.

ELECTRICAL SPECIFICATIONS

- **Current range:**
0.01 A AC .. 12 A AC
- **Output signal:**
100 mVAC/A AC (1.2 V for 12 A)
- **Accuracy and phase shift ⁽¹⁾:**

Primary current	0.01 A .. 0.1 A	0.1 A .. 1 A	1 A .. 5 A	5 A .. 12 A
Accuracy in % of output signal	≤ 3 % + 0.1 mV	≤ 2.5 %	≤ 1 %	
Phase shift	not specified	≤ 5°	≤ 3°	≤ 3°

- **Bandwidth:**
40 Hz .. 10 kHz
- **Crest factor:**
5 for a current of 40 A peak (8 A_{RMS})
- **Maximum currents:**
20 A continuous for a frequency ≤ 10 kHz (limitation proportional to the inverse of one tenth of frequency beyond)
- **Load impedance:**
> 1 MΩ
- **Operating voltage:**
600 V_{RMS}
- **Common mode voltage:**
600 V category III and pollution degree 2
- **Influence of adjacent conductor:**
< 15 mA/A at 50 Hz
- **Influence of conductor position in jaws:**
< 0.5 % of output signal at 50/60 Hz
- **Influence of frequency ⁽²⁾:**
< 5 % of output signal from 20 Hz .. 1 kHz
< 10 % of output signal from 1 kHz .. 10 kHz
- **Influence of crest factor:**
< 3 % of output signal for crest factor < 5 with current < 40 A_{RMS}

MECHANICAL SPECIFICATIONS

- **Operating temperature:**
-10 °C to +55 °C
- **Storage temperature:**
-40 °C to +70 °C
- **Influence of temperature:**
≤ 0.2 % of output signal per 10 °K
- **Relative humidity for operation:**
0 to 85 % RH decreasing linearly above 35 °C
- **Influence of relative humidity:**
< 0.2 % of output signal from 10 % to 85 % RH
- **Operating altitude:**
0 to 2,000 m
- **Max. jaw opening:**
20 mm
- **Clamping capacity:**
Cable: Ø max 20 mm
Busbar: 1 busbar of 20 x 5 mm
- **Casing protection rating:**
IP40 (IEC 529)
- **Drop test:**
1 m (IEC 68-2-32)
- **Shock resistance:**
100 g (IEC 68-2-27)
- **Vibration resistance:**
10/55/10 Hz, 0.15 mm (IEC 68-2-6)

- **Self-extinguishing capability:**
Casing: UL94 V2
Jaws: UL94 V0
- **Dimensions:**
135 x 51 x 30 mm
- **Weight:**
180 g
- **Colours:**
Dark grey case with red jaws
- **Output:**
1.5 m two-wire lead with double or reinforced insulation terminated by 2 elbowed male safety plugs (4 mm)

SAFETY SPECIFICATIONS:

- **Electrical safety:**
Instrument with double insulation or reinforced insulation between the primary the secondary and the grippable part located under the guard as per IEC 1010-1 & IEC 1010-2-032
- 600 V category III, pollution degree 2
- 300 V category IV, pollution degree 2
- **Electromagnetic compatibility (EMC):**
EN 50081-1: class B
EN 50082-2:
- Electrostatic discharge: IEC 1000-4-2
- Radiated field: IEC 1000-4-3
- Fast transients: IEC 1000-4-4
- Magnetic field at 50 Hz: IEC 1000-4-8

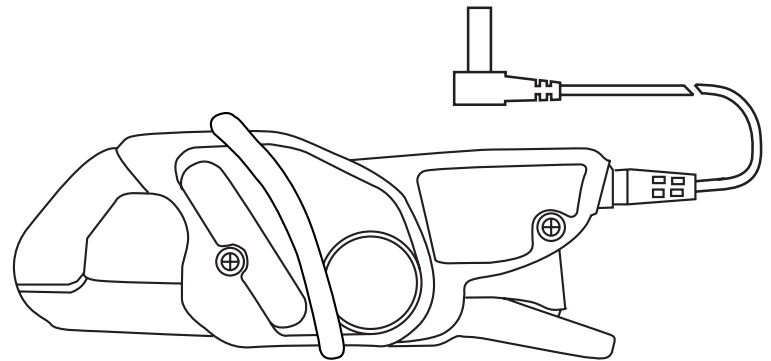

(1) Conditions of reference: 23 °C ± 3 °K, 20 % to 75 % RH, sinusoidal signal with frequency of 48 Hz to 65 Hz, external magnetic field < 40 A/m, no DC components, no external conductor with circulating current, conductor centred for measurement, load impedance > 1 MΩ.

(2) Out of reference domain

To order	Reference
AC current clamp model MN71 with operating manual	P01120420